

When you have a specific requirement, TRS has a specialist solution!



Why your industry can rely on a TRS custom built wheel solution

TRS provide specialist advice and solutions for all transport, industrial and construction applications. TRS staff are able to evaluate specific requirements and consider the many technical factors in conjunction with its in-house design team. All TRS wheels are built to certified standards and backed by a comprehensive warranty.

In addition to our custom manufacture service, TRS stock a huge range of standard fitment wheels for trucks and machinery, providing immediate and cost effective replacement options.

Consider these unique TRS services;

Crack Testing:

Ideal for machinery operating in a safety critical environment, crack testing can also prolong the life of expensive tyres by minimising the risk of premature or unexpected rim failure.



Puncture Proofing:

Avoid the costly down time associated with punctures and prolong the life of your tyres with this revolutionary polymer compound.



Solid Tyre Conversions:

A popular option with waste transfer and demolition operators as a reliable cost effective alternative to tyre fill.



Rough Terrain Forklift Conversions:

Extend the versatility of your forklift or industrial equipment with a conversion to wheel equipment better suited to your specific needs. Many types of conversions are possible.

Specialist Wheel Design and Manufacture:

The TRS design team can provide a design solution to maximise the productivity and utilisation of your machinery. Whether it be replacing fatigued wheels or building a complete custom wheel configuration, TRS have the experience and expertise to provide a fully certified solution.

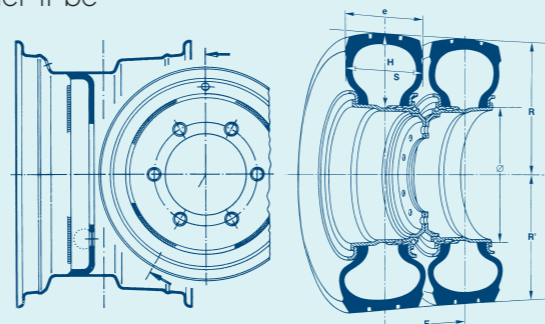

Repair and Modification:

A cost effective alternative to the manufacture of new wheel equipment.

Materials Handling

TRS can supply replacement wheels regardless of machine brand or type of wheel. Options include standard replacement and heavy duty options.



Mining Machinery

TRS can rebuild existing wheel equipment or manufacture replacement wheels to cope with this demanding environment.



Dump Trucks

Whether you require a standard wheel replacement or wider wheels to improve flotation, TRS can engineer a solution.



Graders and Loaders

TRS specialise in the manufacture of wheels utilising the best heavy duty centres and rim bases available to last where original equipment has failed.



Forestry Machinery

Standard on all TRS forestry wheels are features such as reinforced bead sections and valve guards, ensuring reliable performance in such a demanding application.



Power Cranes

Crane conversions to meet footprint requirements are our speciality. All wheels are manufactured from quality heavy duty components.



Specialised Machinery

TRS can build wheels for container handlers, straddle carriers, telescopic handlers and many other types of heavy machinery.



Skid Steer Loaders

TRS manufacture heavy duty wheels, often preferred to the factory originals due to their strength, resulting in significant downtime savings.



All TRS wheel solutions are painted in high gloss enamel in a colour to suit the equipment.

FOR EXPERT ADVICE CALL: 0800 336 334

FOR EXPERT ADVICE CALL: 0800 336 334